

HJD Institute, Kera-Kutch
(We Shape Gems)

2

CUTTING TOOL GEOMETRY

PRODUCTION
TECNOLOGY



Instructional objectives

At the end of this lesson, the student should be able to :

- (a) conceive rake angle and clearance angle of cutting tools
- (b) classify systems of description of tool geometry
- (c) demonstrate tool geometry and define tool angles in :
 - Machine Reference System
 - Orthogonal Rake System and
 - Normal Rake System
- (d) designate cutting tool geometry in ASA, ORS and NRS

Geometry of single point turning tools

Both material and geometry of the cutting tools play very important roles on their performances in achieving effectiveness, efficiency and overall economy of machining.

Cutting tools may be classified according to the number of major cutting edges (points) involved as follows:

- Single point: e.g., turning tools, shaping, planing and slotting tools and boring tools
- Double (two) point: e.g., drills
- Multipoint (more than two): e.g., milling cutters, broaching tools, hobs, gear shaping cutters etc.

(i) Concept of rake and clearance angles of cutting tools.

The word tool geometry is basically referred to some specific angles or slope of the salient faces and edges of the tools at their cutting point. Rake angle and clearance angle are the most significant for all the cutting tools.

The concept of rake angle and clearance angle will be clear from some simple operations shown in Fig. 3.1

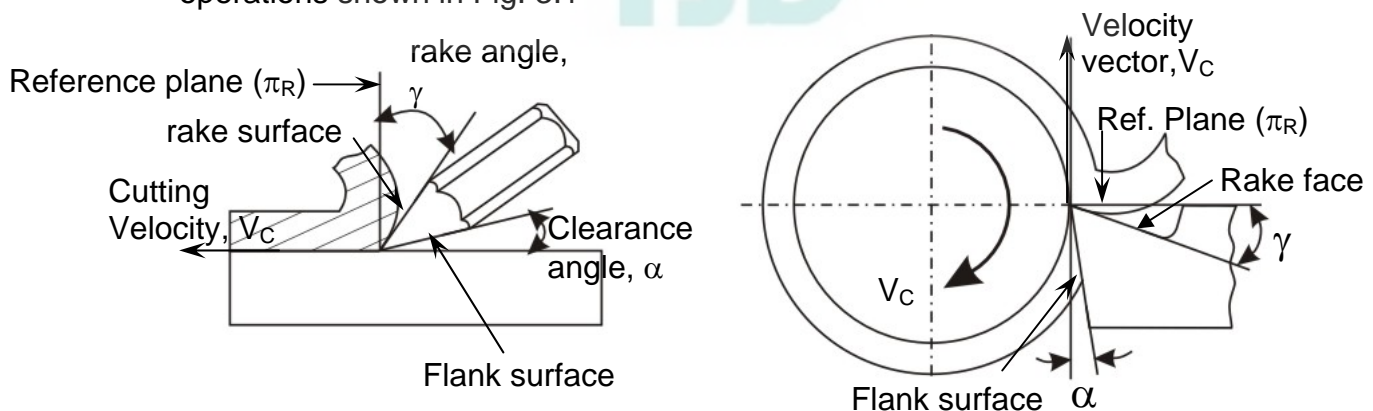

Fig. 3.1 Rake and clearance angles of cutting tools.

- Definition -
- Rake angle (γ): Angle of inclination of rake surface from reference plane
 - clearance angle (α): Angle of inclination of clearance or flank surface from the finished surface

Rake angle is provided for ease of chip flow and overall machining. Rake angle may be positive, or negative or even zero as shown in Fig. 3.2.

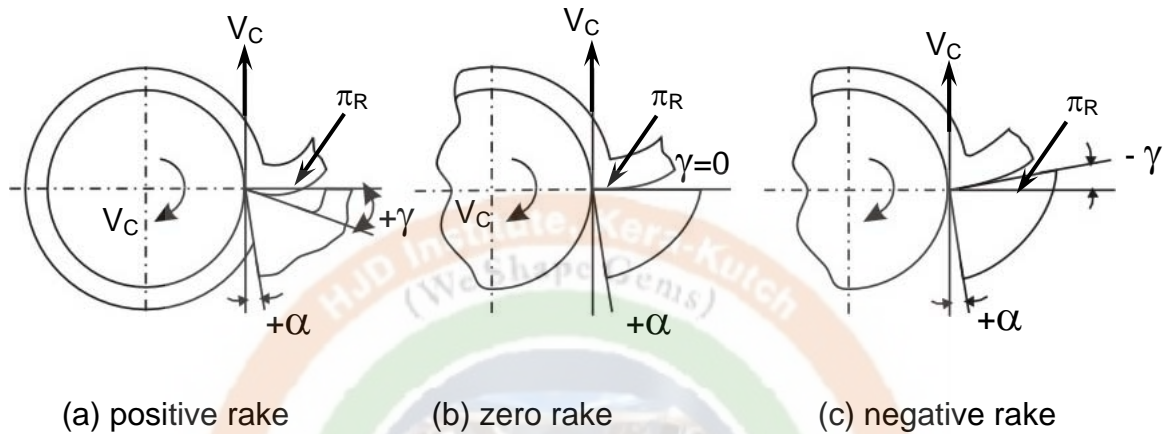

Fig. 3.2 Three possible types of rake angles

Relative advantages of such rake angles are:

- Positive rake – helps reduce cutting force and thus cutting power requirement.
- Negative rake – to increase edge-strength and life of the tool
- Zero rake – to simplify design and manufacture of the form tools.

Clearance angle is essentially provided to avoid rubbing of the tool (flank) with the machined surface which causes loss of energy and damages of both the tool and the job surface. Hence, clearance angle is a must and must be positive ($3^\circ \sim 15^\circ$ depending upon tool-work materials and type of the machining operations like turning, drilling, boring etc.)

(ii) Systems of description of tool geometry

- Tool-in-Hand System – where only the salient features of the cutting tool point are identified or visualized as shown in Fig. 3.3. There is no quantitative information, i.e., value of the angles.
- Machine Reference System – ASA system
- Tool Reference Systems
 - * Orthogonal Rake System – ORS
 - * Normal Rake System – NRS
- Work Reference System – WRS

(iii) Demonstration (expression) of tool geometry in :

- **Machine Reference System**

This system is also called ASA system; ASA stands for American Standards Association. Geometry of a cutting tool refers mainly to its

several angles or slope of its salient working surfaces and cutting edges. Those angles are expressed w.r.t. some planes of reference. In Machine Reference System (ASA), the three planes of reference and the coordinates are chosen based on the configuration and axes of the machine tool concerned. The planes and axes used for expressing tool geometry in ASA system for turning operation are shown in Fig. 3.4.

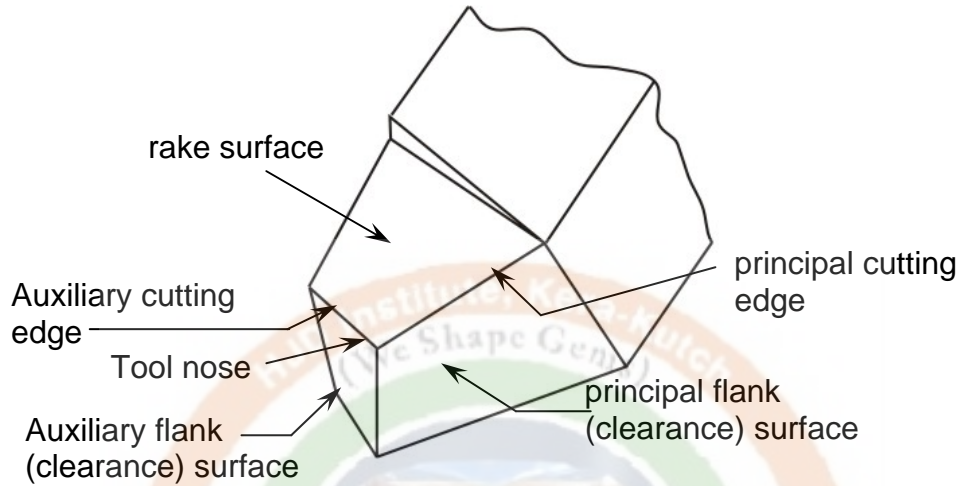

Fig. 3.3 Basic features of single point tool (turning) in Tool-in-hand system

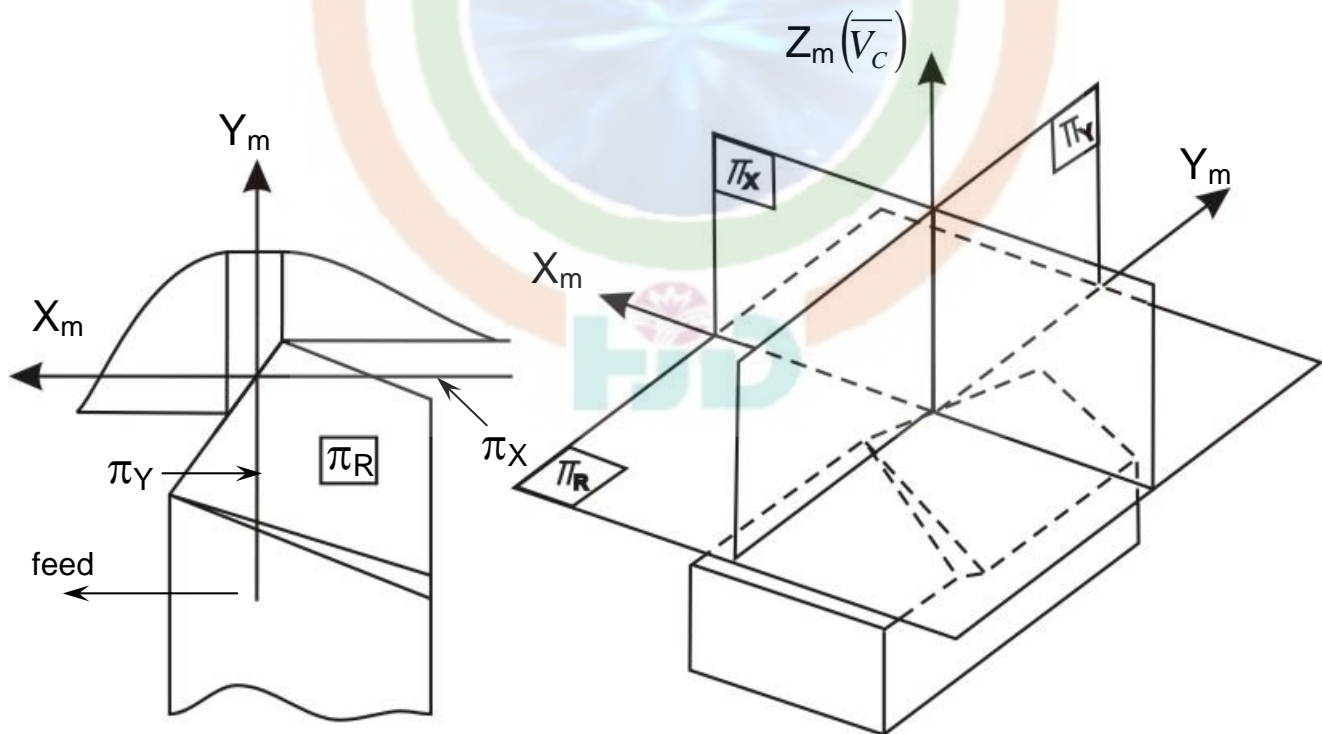

Fig. 3.4 Planes and axes of reference in ASA system

The planes of reference and the coordinates used in ASA system for tool geometry are :

$$\pi_R - \pi_X - \pi_Y \text{ and } X_m - Y_m - Z_m$$

where,

π_R = Reference plane; plane perpendicular to the velocity vector
(shown in Fig. 3.4)

π_X = Machine longitudinal plane; plane perpendicular to π_R and taken
in the direction of assumed longitudinal feed

π_Y = Machine Transverse plane; plane perpendicular to both π_R and π_X
[This plane is taken in the direction of assumed cross feed]

The axes X_m , Y_m and Z_m are in the direction of longitudinal feed, cross feed
and cutting velocity (vector) respectively. The main geometrical features and
angles of single point tools in ASA systems and their definitions will be clear
from Fig. 3.5.

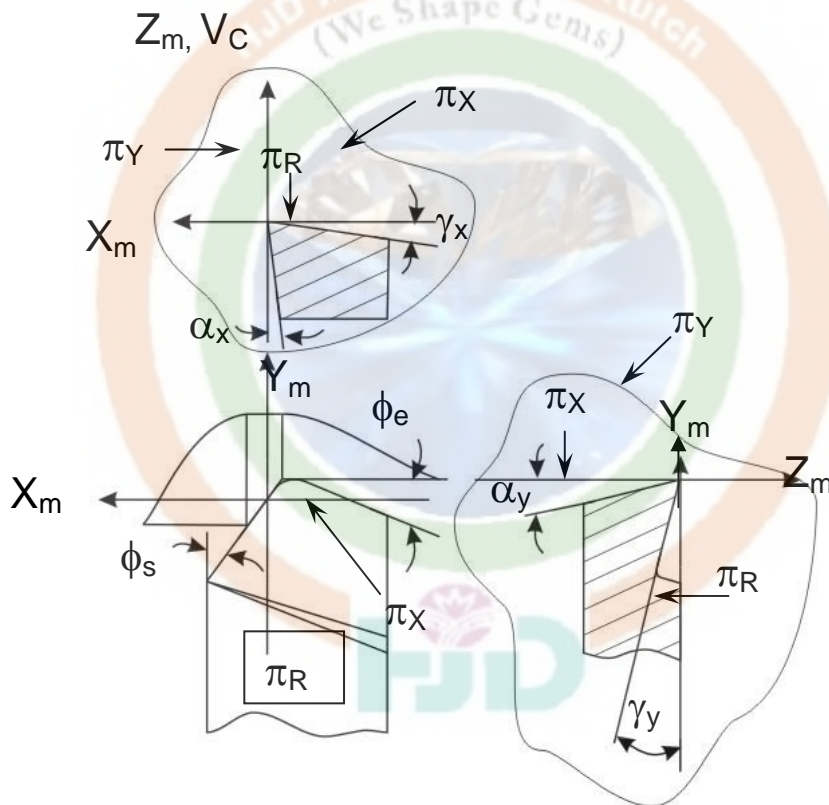

Fig. 3.5 Tool angles in ASA system

Definition of:

- Rake angles: [Fig. 3.5] in ASA system

γ_x = side (axial rake: angle of inclination of the rake surface from the
reference plane (π_R) and measured on Machine Ref. Plane, π_X .

γ_y = back rake: angle of inclination of the rake surface from the reference
plane and measured on Machine Transverse plane, π_Y .

- Clearance angles: [Fig. 3.5]

α_x = side clearance: angle of inclination of the principal flank from the machined surface (or $\overline{V_c}$) and measured on π_x plane.

α_y = back clearance: same as α_x but measured on π_y plane.

- Cutting angles: [Fig. 3.5]

ϕ_s = approach angle: angle between the principal cutting edge (its projection on π_R) and π_Y and measured on π_R

ϕ_e = end cutting edge angle: angle between the end cutting edge (its projection on π_R) from π_x and measured on π_R

- Nose radius, r (in **inch**)

r = nose radius : curvature of the tool tip. It provides strengthening of the tool nose and better surface finish.

- **Tool Reference Systems**

- **Orthogonal Rake System – ORS**

This system is also known as ISO – old.

The planes of reference and the co-ordinate axes used for expressing the tool angles in ORS are:

$\pi_R - \pi_C - \pi_O$ and $X_o - Y_o - Z_o$

which are taken in respect of the tool configuration as indicated in Fig. 3.6

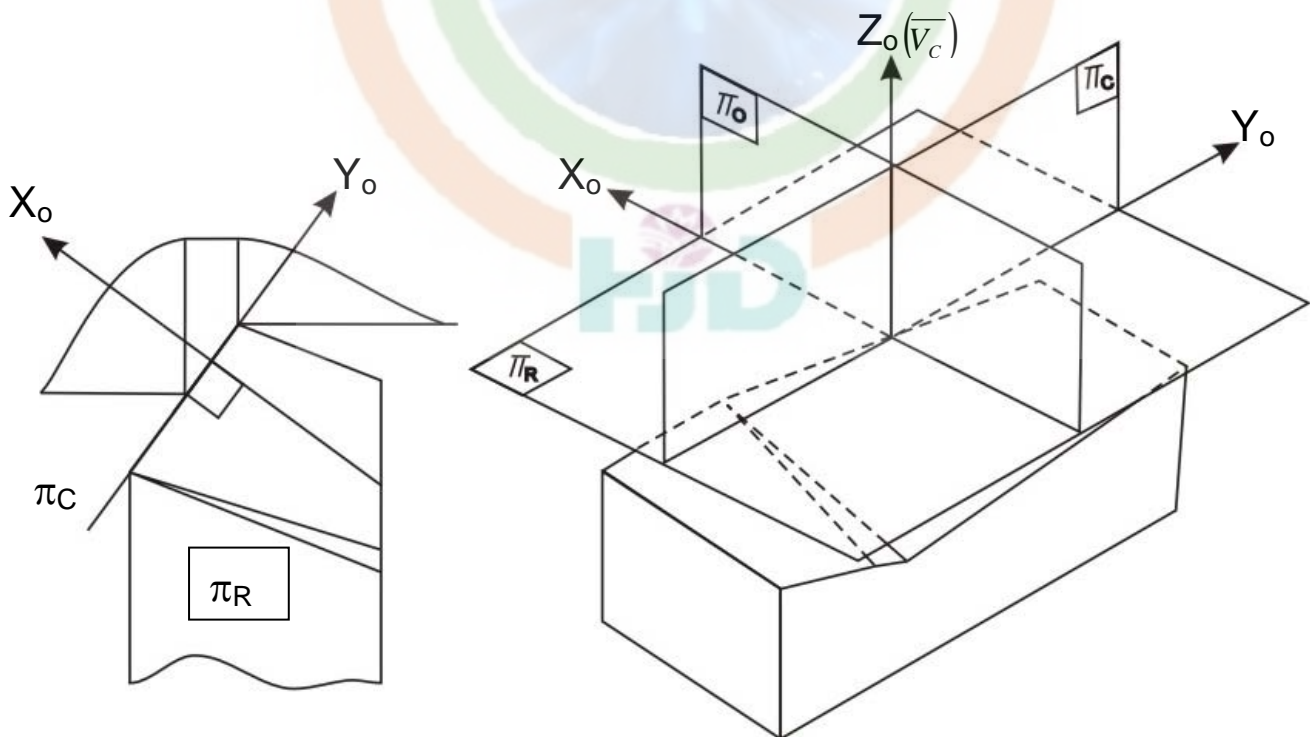

Fig. 3.6 Planes and axes of reference in ORS

where,

π_R = Reference plane perpendicular to the cutting velocity vector, $\overline{V_C}$

π_C = cutting plane; plane perpendicular to π_R and taken along the principal cutting edge

π_O = Orthogonal plane; plane perpendicular to both π_R and π_C and the axes;

X_o = along the line of intersection of π_R and π_O

Y_o = along the line of intersection of π_R and π_C

Z_o = along the velocity vector, i.e., normal to both X_o and Y_o axes.

The main geometrical angles used to express tool geometry in Orthogonal Rake System (ORS) and their definitions will be clear from Fig. 3.7.

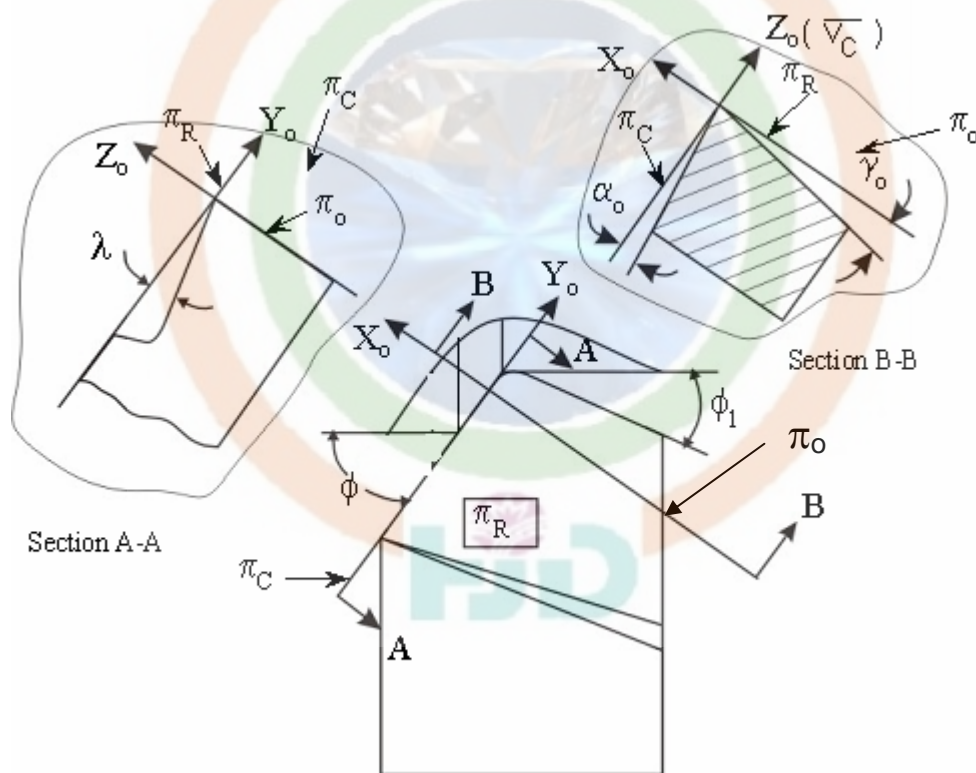

Fig. 3.7 Tool angles in ORS system

Definition of –

- Rake angles [Fig. 3.7] in ORS

γ_o = orthogonal rake: angle of inclination of the rake surface from Reference plane, π_R and measured on the orthogonal plane, π_o

λ = inclination angle; angle between π_C from the direction of assumed longitudinal feed [π_X] and measured on π_C

- Clearance angles [Fig. 3.7]

α_o = orthogonal clearance of the principal flank: angle of inclination of the principal flank from π_C and measured on π_o

α_o' = auxiliary orthogonal clearance: angle of inclination of the auxiliary flank from auxiliary cutting plane, π_C' and measured on auxiliary orthogonal plane, π_o' as indicated in Fig. 3.8.

- Cutting angles [Fig. 3.7]

ϕ = principal cutting edge angle: angle between π_C and the direction of assumed longitudinal feed or π_X and measured on π_R

ϕ_1 = auxiliary cutting angle: angle between π_C' and π_X and measured on π_R

- Nose radius, r (mm)

r = radius of curvature of tool tip

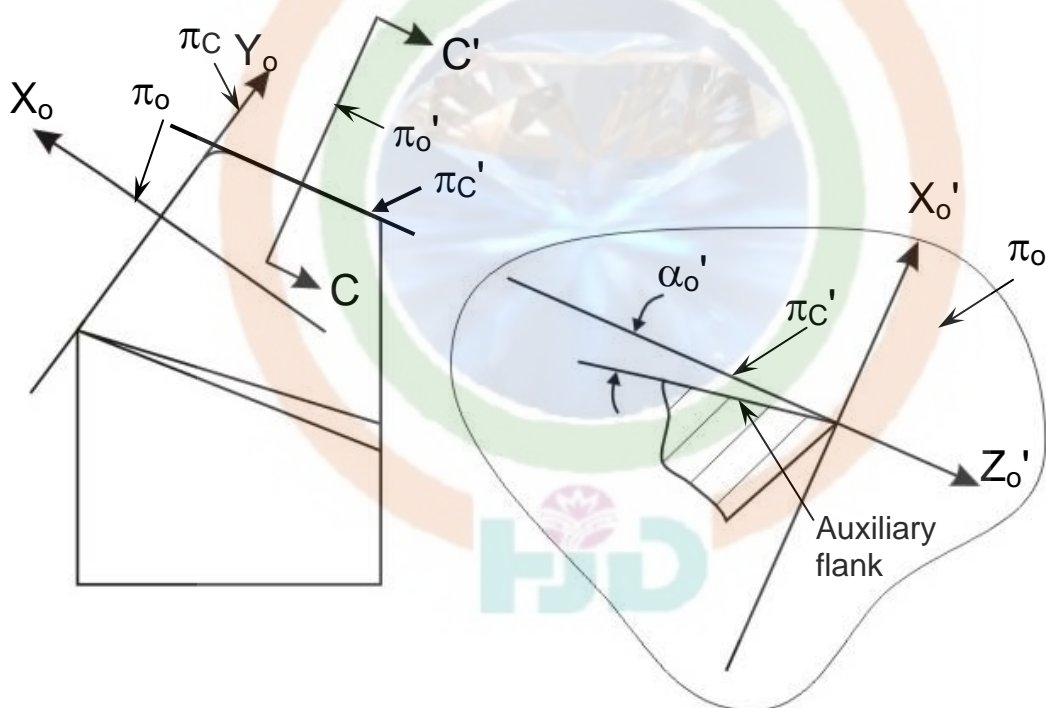

Fig. 3.8 Auxiliary orthogonal clearance angle

- **Normal Rake System – NRS**

This system is also known as ISO – new.

ASA system has limited advantage and use like convenience of inspection. But ORS is advantageously used for analysis and research in machining and tool performance. But ORS does not reveal the true picture of the tool geometry when the cutting edges are inclined from the reference plane, i.e., $\lambda \neq 0$. Besides, sharpening or reshaping, if necessary, of the tool by grinding in ORS requires some additional calculations for correction of angles.

These two limitations of ORS are overcome by using NRS for description and use of tool geometry.

The basic difference between ORS and NRS is the fact that in ORS, rake and clearance angles are visualized in the orthogonal plane, π_o , whereas in NRS those angles are visualized in another plane called Normal plane, π_N . The orthogonal plane, π_o is simply normal to π_R and π_C irrespective of the inclination of the cutting edges, i.e., λ , but π_N (and π_N' for auxiliary cutting edge) is always normal to the cutting edge. The differences between ORS and NRS have been depicted in Fig. 3.9.

The planes of reference and the coordinates used in NRS are:

$$\pi_{RN} - \pi_C - \pi_N \text{ and } X_n - Y_n - Z_n$$

where,

π_{RN} = normal reference plane

π_N = Normal plane: plane normal to the cutting edge

and

$X_n = X_o$

Y_n = cutting edge

Z_n = normal to X_n and Y_n

It is to be noted that when $\lambda = 0$, NRS and ORS become same, i.e. $\pi_o \cong \pi_N$, $Y_N \cong Y_o$ and $Z_n \cong Z_o$.

Definition (in NRS) of

- Rake angles

γ_n = normal rake: angle of inclination of the rake surface from π_R and measured on normal plane, π_N

α_n = normal clearance: angle of inclination of the principal flank from π_C and measured on π_N

α_n' = auxiliary clearance angle: normal clearance of the auxiliary flank (measured on π_N' – plane normal to the auxiliary cutting edge).

The cutting angles, ϕ and ϕ_1 and nose radius, r (mm) are same in ORS and NRS.

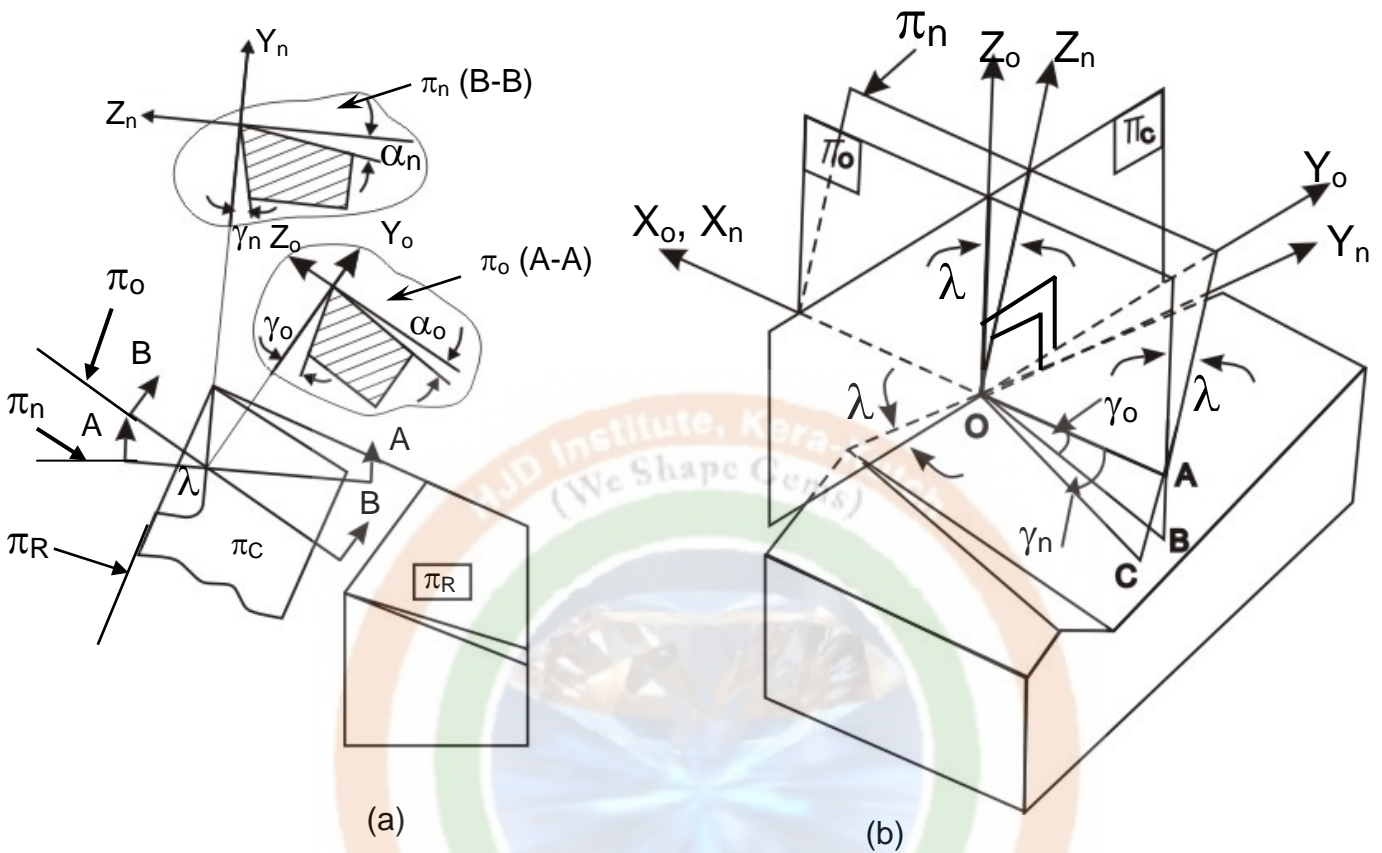

Fig. 3.9 Differences of NRS from ORS w.r.t. cutting tool geometry.

(b) Designation of tool geometry

The geometry of a single point tool is designated or specified by a series of values of the salient angles and nose radius arranged in a definite sequence as follows:

Designation (signature) of tool geometry in

- ASA System –
 $\gamma_y, \gamma_x, \alpha_y, \alpha_x, \phi_e, \phi_s, r$ (inch)
- ORS System –
 $\lambda, \gamma_o, \alpha_o, \alpha_o', \phi_1, \phi, r$ (mm)
- NRS System –
 $\lambda, \gamma_n, \alpha_n, \alpha_n', \phi_1, \phi, r$ (mm)